

DRAWING NO. SD034764		7		6		5		4		3		2		1										
BURNDY® CATALOG NUMBER	COPPER AIRCRAFT CABLE MIL-W-5086	MS20659 DASH NUMBER	STUD SIZE	B MIN.	C ±.020	L MAX.	N ±.010	R REF.	T ±.020	Y MAX.	Z MIN.	INSTALL. TOOL INDEX NUMBER	REV	DATE	DESCRIPTION	ECO	BY	C'H'K.						
YAV2C-L3	AN-2	146	10	.595	.688	1.722	.344	.69	.091	1.373	.349	41	J	03/11/2015 00:00:00 AM	UPDATED C & T DIMENSIONS FOR CAT. YAVICL3	39458	BSB	RG						
YAV2C-L1		113	1/4	↑	↓	1.722	.344	↑	.091	1.373	.349	↑												
YAV2C-L2		147	5/16			1.722	.344		.091	1.373	.349													
YAV2C-L		114	3/8			1.722	.344		.091	1.373	.349													
YAV2C-L23		---	3/8			.688	1.868		.344	.091	1.519		.495											
YAV2C-L19		---	3/8			.665	1.943		.325	.094	1.613		.589											
YAV2C-L26		---	3/8-10MM			.688	1.722		.344	.091	1.373		.349											
YAV2C-L11		148	7/16			.770	1.878		.385	.079	1.488		.464											
YAV2C-L4		133	1/2			.770	1.878		.385	.079	1.488		.464											
YAV2C-L22		---	1/2			.770	2.082		.385	.079	1.692		.668											
YAV2C-L38		---	3/4			.595	1.250		2.337	.625	.75		.051	1.707	.683	41								
YAV2CL-L56		---	1/2			.725	.830		2.100	.406	.75		.120 MIN	1.685	.551	41								
YAVIC-L6		AN-1	---			10	.595		.760	1.666	.344		.75	.109	1.317	.246	42							
YAVIC-L1			115			1/4	↑		↓	1.839	.380		↑	.109	1.454	.383	↑							
YAVIC-L2			149			5/16				1.839	.380			.109	1.454	.383								
YAVIC-L	116		3/8			1.839				.380	.109			1.454	.383									
YAVIC-L12	---		3/8-10MM	.760	1.759	.344		.109		1.410	.339													
YAVIC-L4	150		7/16	.860	1.970	.430		.102		1.535	.464													
YAVIC-L3	134		1/2	.840	1.970	.430		.100		1.535	.464													
YAVIC-L5	---		5/8	1.060	2.431	.500		.099		1.926	.855													
YAVIC-L18	---	3/8	.595	.760	1.989	.380		.75		.109	1.604	.530		42										
YAV25-L5	AN-1/0	---	10	.658	.830	1.988	.375	.75	.110	1.608	.428	43												
YAV25-L29		---	10-5MM	↑	↓	1.988	.375	↑	.110	1.608	.428	↑												
YAV25-L1		117	1/4			2.028	.415		.110	1.608	.428													
YAV25-L2		151	5/16			2.028	.415		.110	1.608	.428													
YAV25-L		118	3/8			.830	2.028		.415	.110	1.608		.428											
YAV25-L15		---	3/8			.687	1.852		.343	.140	1.504		.324											
YAV25-L26		---	3/8			.880	2.089		.440	.104	1.644		.464											
YAV25-L30		---	3/8			.830	2.830		.390	.110	2.435		1.255											
YAV25-L28		---	3/8-10MM			.830	2.028		.390	.110	1.608		.428											
YAV25-L16		152	7/16			.880	2.089		.440	.105	1.644		.464											
YAV25-L3		135	1/2			.880	2.089		.440	.105	1.644		.464											
YAV25-L4		---	5/8			.880	2.305		.500	.105	1.800		.620											
YAV25-L23		---	3/4			.953	2.490		.625	.093	1.860		.680											
YAV25-L16G1		---	7/16			.830	2.089		.440	.110	1.644		.464											
YAV25-L362		---	1/2			.830	2.089		.440	.110	1.644		.464											
YAV25-L39	---	1/2	.658			.973±.040	2.089		.440	.75	.188 REF.		1.644	.464	43									

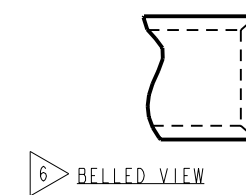
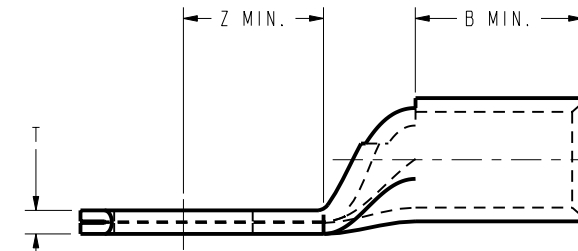
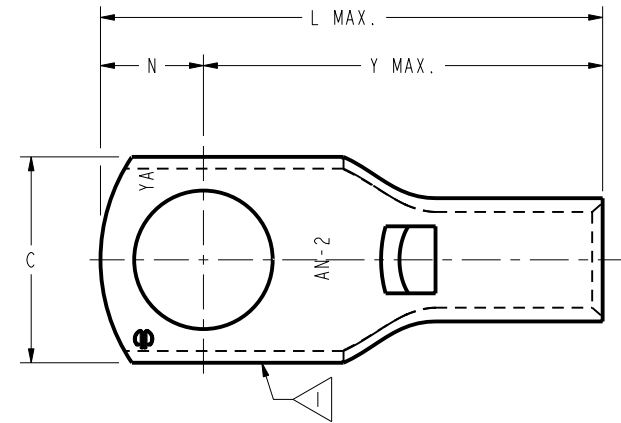

NOTES:

- 1 DUE TO METHODS OF MANUFACTURING, SERRATIONS APPEAR ON TONGUE.
2. MATERIAL: COPPER TUBING
3. FINISH: TIN PLATED 5
4. ALL ITEMS ARE LISTED BY UNDERWRITERS LABS PER CONTROL NUMBER 670-B, FILE NUMBER E9498, WHITE CARD. (DOES NOT APPLY TO YAV--L-G).
- 5 ADD SUFFIX "-NK" FOR NICKEL PLATING.
- 6 ADD SUFFIX "B" FOR BELLED BARREL. BELLED VERSIONS OF THESE HYLUGS™ DON'T CONFORM TO THE MS20659 DASH NO.

REV: PE0200

TO ORDER BURNDY® PRC		HYLUG™	
ITEM NO:	N/A	SCALE: 3:1	
CAT. NO:	YAVL (SEE TABLE)	DRAWING NO	
DRAWN BY:	ESK 02-02-73	SD034764	REV
CHECKER:	TB 06-01-77		J
DSN APPVL:	TB 06-01-77	SHEET 2 OF 3	
MFG APPVL:	--		
QA APPVL:	--		
MKT APPVL:	--		
PROD FAM:	PROD./SMALL COMPRE.		
PROJECT #:	---		
DOCUMENT TYPE:	Sales		
REL LEVEL:	Released		